

Français:

Attention - Suivez la séquence d'instructions d'assemblage.

Appliquer l'item N°6 (Bande de Protection – x1) sur l'intérieur de la partie centrale de la protection afin de rester entre le châssis de la moto et la protection en aluminium.

- **Photo A:** Retirer les vis OEM (2x – côté gauche et droit).
- **Photo B:** Appliquer les items N°3 (Clip Inox – x2) et N°4 (Capsule Caoutchouc – x2) sur l'item N°5 (Fixation Inox – x1) et monter sur la partie avant du cadre de la moto.
- **Photo C:** Monter la protection sur la moto première partie arrière avec l'item N°1 (Vis – x2).
- **Photo D:** Apply item N°2 (Vis – x2) sur la partie avant de la protection sur l'item N°5 (Fixation Inox) précédemment monté.

Torque toutes les vis avec la bonne valeur.

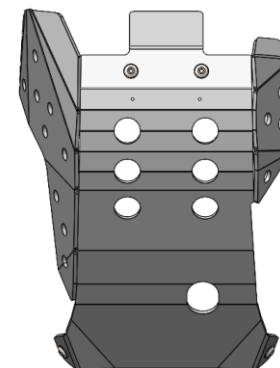

ALUMINUM EC ENGINE GUARD

Ref.: 2CP059230A



Assembly Booklet / Paper collection

Livret de montage / Collecte de papier



Mini Zip Bag / Plastic collection

Mini sac zip / Collecte de plastique



Box / Paper collection

Boîte / Collecte de papier



Carton Separator / Paper collection

Séparateur de cartons / Collecte de papier



Card Header / Paper collection

Carte d'en-tête / Collecte de papier



Plastic Bag Cover / Plastic collection

Couverte de sac en plastique / Collecte de plastique



ASSEMBLY SEQUENCE / INSTRUÇÃO DE MONTAGEM



4mm

T25

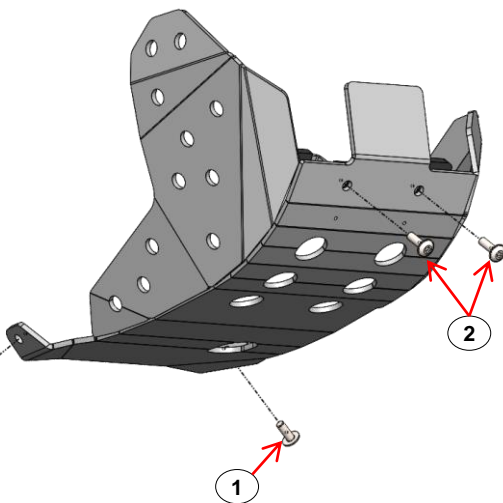
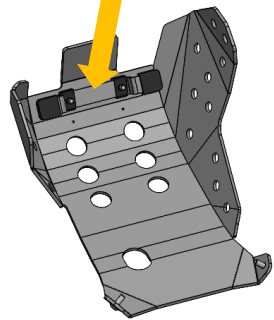
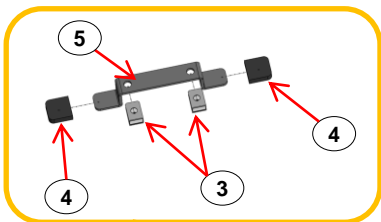

N.m	M4	M5	M6	M8	M10	M12
STEEL	8.8	2.7	5.5	9.7	23.0	47.0
STAINLESS STEEL	A2	2.6	5.1	8.7	21.2	42.0

ITEM Nº:	COMPONENTE (COMPONENT):	DESCRIÇÃO (DESCRIPTION):	QUANT.:
6	Tira Protetora / Protective Strip	1 Mt.	1
5	Fixação Inox / Inox Clamp	Nº116	1
4	Cápsula de Borracha / Rubber Cap	.	2
3	Mola de Friso / Clip Inox	M6	2
2	Paraf. Cabeça Redonda Sext. Int. c. FA / Round Head Screw With Washer False	M6x20 - ISO 7380	2
1	Paraf. Cabeça Redonda Sext. Int. c. FA / Round Head Screw With Washer False	M6x16 - ISO 7380	2
ACESSÓRIOS (ACCESSORIES)			

English:

Attention – Follow the assembly instruction sequence.

Apply item N°6 (Protective Strip – x1) on the inside of the central part of the protection in order to stay between the frame of the bike and the aluminum protection.

- **Photo A:** Remove OEM screws (2x – left and right side).
- **Photo B:** Apply items N°3 (Clip Inox – x2) and N°4 (Rubber Cap – x2) on item N°5 (Inox Clamp – x1) and mount assembly on the front part of the bike frame.
- **Photo C:** Mount protection first rear part with item N°1 (Screw – x2).
- **Photo D:** Apply item N°2 (Screw – x2) on the front part of the protection in item N°5 (Inox Clamp) previously mounted.

Torque all screws to the correct value.

ALUMINUM EC ENGINE GUARD

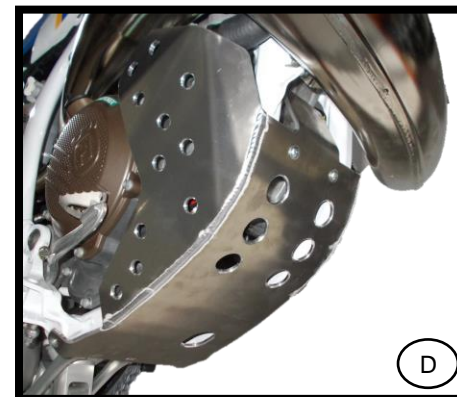
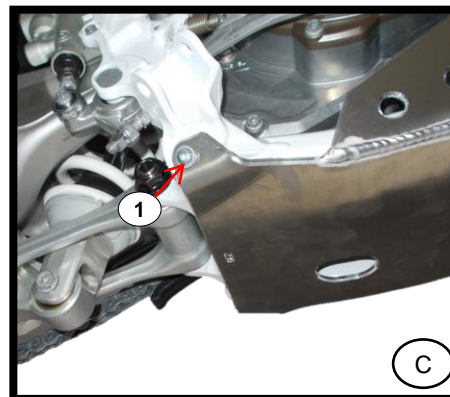
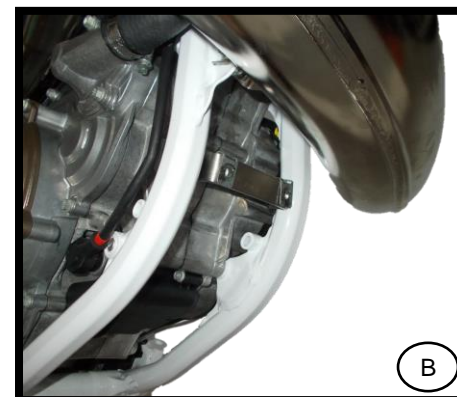
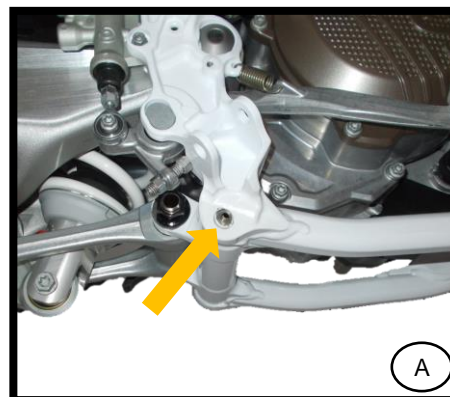

Português:

Atenção – Siga a seqüência de instrução de montagem.

Aplicar item N°6 (Tira Protetora – x1) no interior da parte central da proteção de forma a ficar entre a proteção de alumínio e o quadro da moto.

- **Foto A:** Remover parafusos OEM (2x – lado esquerdo e direito).
- **Foto B:** Aplicar os itens N°3 (Mola de Friso – x2) e N°4 (Cápsula de Borracha – 2) no item N°5 (Fixação Inox – x1) e montar assemblagem na parte da frente do quadro da moto.
- **Foto C:** Montar proteção iniciando pela parte de trás com o item N°1 (Parafuso – x2).
- **Foto D:** Aplicar o item N°2 (Parafuso – x2) na parte da frente da proteção no item N°5 (Fixação Inox) anteriormente montado.

Apertar todos os parafusos com o valor correto de torque.